

Product Transition Guide GPD 506/P5 to P7



PL.P7.06.TransitionP5

Product Transition Guide

GPD506/P5 to P7

NOTICE

The information contained within this document is the proprietary property of Yaskawa Electric America, Inc., and may not be copied, reproduced or transmitted to other parties without the expressed written authorization of Yaskawa Electric America, Inc. No patent liability is assumed with respect to the use of the information contained herein. Moreover, because Yaskawa is constantly improving its high-quality products, the information contained in this document is subject to change without notice. Every precaution has been taken in the preparation of this document. Nevertheless, Yaskawa assumes no responsibility for errors or omissions. Neither is any liability assumed for damages resulting from the use of the information contained in this publication.

Contents

FEATURE OVERVIEW	5
BENEFITS OF THE NEW P7 WHEN COMPARED TO GPD506/P5	5
NEW/ADDITIONAL P7 PARAMETER FUNCTIONS NOT PRESENT IN THE GPD506/P5	5
P7 DIGITAL INPUTS (ADDITIONAL FUNCTIONS).....	6
P7 DIGITAL INPUTS (ADDITIONAL FUNCTIONS).....	6
P7 ANALOG INPUT (ADDITIONAL FUNCTIONS).....	6
P7 DIGITAL OUTPUT RELAY (ADDITIONAL FUNCTIONS).....	6
P7 ANALOG OUTPUTS (ADDITIONAL FUNCTIONS).....	6
P7 SERIAL COMMUNICATIONS	7
P7 START-UP, INSTALLATION & MAINTENANCE IMPROVEMENTS.....	7
P7 ADDITIONAL HARDWARE PROTECTION	7
REASONS TO CONTINUE GPD506/P5	7
GPD506/P5 TO P7 SPECIFICATION DIFFERENCES	9
DIGITAL OPERATOR COMPARISON	12
GPD506/P5 TO P7 TERMINAL COMPARISON.....	13
NETWORK COMMUNICATIONS	17
DETAILS ON NEW P7 FEATURES & FUNCTIONS	18
APPENDIX 1	19
RATINGS AND HEAT LOSS COMPARISON	19
NEC HP RATINGS FOR 240V NORMAL DUTY MODELS	21
NEC HP RATINGS FOR 480V NORMAL DUTY MODELS	22
HEAT LOSS DATA.....	23
APPENDIX 2	25
MECHANICAL DIMENSIONS	25
PANEL CUT-OUT FOR EXTERNAL HEATSINK MOUNTING	27
MOUNTING HOLE DATA.....	28
APPENDIX 3 – PARAMETER CROSS REFERENCE.....	29

Product Transition Guide

GPD506/P5 to P7

Page Intentionally Left Blank

Feature Overview

This document details differences between the GPD506/P5 and P7 product to assist in product transition and new product introduction.



GPD506/P5 Drive

The GPD 506/P5 inverter is intended for fan and pump applications in Building and Industrial Automation. It is available in constant and variable torque ratings, 3/4 to 500 horsepower.



P7 Drive

The P7 drive is an ideal choice for industrial applications, such as centrifugal fans and pumps. The P7 drive is provided in Normal Duty ratings with 110% overload capability. V/f control mode, network communication options, and an array of input/output choices are available.

Benefits of the New P7 When Compared to GPD506/P5

New/Additional P7 Parameter Functions not Present in the GPD506/P5

- New Motor preheat function with adjustable current setting to prevent condensation in motor, (b2-09)
- P7 is flash memory upgradeable
- Accel/Decel range now adjustable from 0.1 to 6000 sec. (GPD506/P5 max. range is 3600)
- Critical frequency rejection: 3 selectable, adjustable bands, d3-03—Jump frequency 3 (additional) (GPD506/P5 only has two)
- New Wait To Run Timer function allowing output of drive to delay start after a Run command (b1-11)
- Torque boost with adjustable filter time for better torque compensation response (C4-02)
- Power loss ride-thru time settable to 25 sec. (GPD506/P5 is 2 sec. Max.)
- Auto restart now has maximum restart time after fault if fault condition doesn't clear during the first try
- New "Up/Down" floating point control capability
- Primary resistance auto-tuning
- Customizable monitor display
- Run permissive input

- New PI Snooze function available in conjunction with Sleep mode (b5-21)
- Adjustable Undervoltage Detection level (L2-05) not available in GPD506/P5
- Speed search function with new Speed Estimation mode and Bi-directional search mode (b3-01)
- New Setpoint PI features include:
 - Two feedback capability, Output Limit, Offset adjustment, Primary delay, Output gain, Output reverse, Setpoint accel/decel, Setpoint display scaling, Selectable sleep input source, Snooze function, Setpoint boost, Fdbk square root function with output monitor. (b5-06, b5-07, b5-08, b5-10, b5-11, b5-17 thru 30)
 - Separately adjustable e-stop times (C1-09)
 - Accel/decel rate switchover via output frequency (C1-11)
 - 14 more V/f presets than GPD506/P5 for a total of 15 V/f preset patterns (E1-03)
 - Mid frequency and voltage V/f points on the custom V/f pattern (E1-11,12)
 - Trim speed control function (d4-02)

New/Additional P7 Parameter Functions not Present in the GPD506/P5

Product Transition Guide

GPD506/P5 to P7



Motor thermistor input with temperature filter and selectable fault ,alarm settings (L1-02 to L1-05)

Intelligent stall prevention on accel/decel with decel time 1 or 2 selections (L3-01,4,5)

Extended 0.5 to 600.0 sec. auto-restart time between attempts vs. 10.0 secs for GPD506/P5 (L5-03)

Hunting prevention function (n1-01,2)

DC Injection braking (b1-03)

Run command can be accepted

while the drive is being programmed (b1-08)

High slip braking function (n3-01,2,3,4)

Selectable power-up monitor (o1-01,2)

Keypad display contrast adjustment (o1-05)

Two independent programmable over and under torque detection levels

P7 Digital Inputs (Additional Functions)

One more digital input for a total of seven

More versatile PNP/NPN sinking/sourcing 24 VDC control logic

Transmitter/option power supply

29 more programmable functions for digital inputs than GPD506/P5. 59 total :

Motor Preheat

MOP increase/decrease function

Forward and reverse jog input

Trim control increase and decrease functions

15 additional external fault action settings such as Fast-stop, Alarm only, Coast to stop with selectable N.O or N.C. for each fault action.

PI integral hold and PI cancel functions

Speed search 3

Serial Communication test mode

High slip braking input

Jog 2

P7 Digital Inputs (Additional Functions)

Drive enable, with selectable accept run command or cycle run command function

P7 Analog Input (Additional Functions)

A convenient PCB switch now changes analog input A2 between current and voltage, cutting PCB jumper for mA signal is no longer required.

Adjustable analog input signal filter for added stability

Terminal A2 is selectable for :

Frequency bias

Motor thermister

PI differential

Analog input filter

Main and Aux frequency reference is selectable between terminals A1 and A2

P7 Digital Output Relay (Additional Functions)

27 possible programmable functions for the digital outputs, seven more than the GPD506/P5.

One additional relay output, M3 and M4 relays

DC bus under voltage output

Reset command active output

Reverse direction output

Drive enable output

OH frequency reduction output

Restart Enabled

P7 Analog Outputs (Additional Functions)

Additional AM analog monitor output with bias and gain settings.

Analog monitors now selectable between 0-10V and 4-20ma, GPD506/P5 only 0-10V

18 programmable selections for the analog outputs, 14 more than the GPD506/P5.

Frequency reference monitor

Terminal A1 or A2 monitor

Motor SEC current monitor

SFS output monitor

PI- feedback, input, output and setpoint monitors

PI feedback 2 monitor

Output Voltage

Product Transition Guide

GPD506/P5 to P7



P7 Serial Communications

Built-in RS-485/422 modbus serial communications
Optional communication interface: Devicenet, Profibus, and others
Serial communications loss detection timeout function
Drive Wizard upload/download and monitoring /graphing software

P7 Start-up, Installation & Maintenance Improvements

Control terminal board: Quick disconnect
Enhanced digital keypad, 5 Line x 16 Character LCD (Std)
6 new languages can be displayed on the keypad. GPD506/P5 has only English (A1-00)
User password protection for 32 customizable user parameters (A1-04)
A2-01 thru A2-32—User access level provides 32 user selectable parameters.
Parameter copy function to another P7 using standard digital operator (o3-01)
Improved fault storage, last 10 faults
Quick disconnect I/O blocks for easy wiring
Logged cooling fan hours for scheduled maintenance
Modular cooling fan for easy replacement
Automatic cooling fan run control to extend fan life

P7 Additional Hardware Protection

Adjustable heat-sink overheat pre-alarm level (L8-02)
Selectable ground fault detection (L8-09)
Selectable cooling fan operation with off delay (L8-10,11)
Automatic ambient temperature compensation to protect the drive in environments exceeding its rating (L8-12)
Adjustable OH frequency reference reduction (L8-19)
Adjustable motor overload time constant (L1-02)

**Product Transition Guide
GPD506/P5 to P7**

Page left intentionally blank

Product Transition Guide GPD506/P5 to P7

GPD506/P5 to P7 Specification Differences

Feature or Function	Item	Yaskawa GPD506/P5	Yaskawa P7
Performance Features			
HP Range Note: The voltage rating in the "Item" column is generalized. Refer to the Service Conditions section for rated input voltage requirements.	240V	0.75 to 125HP (VT)	5 to 150HP (ND2)
	480V	0.75 to 500HP (VT)	5 to 500HP (ND2)
	600V	2 to 200HP (VT)	Available w/GPD506/P5 Not Available in P7
Overload Rating	% for Minutes	150% for 1 min (CT) 200% peak 120% for 1 min (VT) 180% peak	110% for 1 min (ND2) 150% peak
PWM Carrier Frequency	Range	See Carrier Frequency Table	See Carrier Frequency Table
Max. Output Frequency	Hz	400Hz	0 To 120Hz
Speed Range	V/f	40:1	40:1
Protective Features			
Heat Sink Temperature Fault	Fault Action	Coast, Ramp, Continue	--Coast, Ramp, Continue or Continue with reduced speed --OH Pre-alarm level setting
Design Features			
Keypad Design	Qty of keys	7	11
	Language	1	7 (w/LCD)
	Copy Function	No	Yes
	Display	LCD display, alpha numeric, 16 char x 2 lines	LCD display, alpha numeric, 16 char x 5 lines, backlit

Product Transition Guide

GPD506/P5 to P7

GPD506/P5 to P7 Specification Differences (continued)

Feature or Function	Item	Yaskawa GPD506/P5	Yaskawa P7
Design Features (continued)			
Network Communications	Standard	Modbus RTU via RS232	Modbus RTU via built in RS485/422
	Optional	RS232 to RS485, DeviceNet, Lonworks, ApogeeFLN, MetasysN2	DeviceNet, Profibus-DP, Lonworks, Ethernet
Diagnostics	Fault Storage	Last 4 Faults	Last 10 Faults with Elapsed Time, Most Recent Fault with all Operating Conditions
Quick Disconnect I/O Terminals	Type	No	Yes (Phoenix) With split front cover for easy wiring
Auto-Tuning	Rotating/Stationary	No	Primary resistance auto-tuning
Speed Search Synchronized Start	Bi/Uni-Directional	Uni-Directional	Bi-Directional
	Method	Current	Current/Speed
PI / PID Control	Analog Input Signal Filter	No	Yes
	Two Feedback	No	Yes
Sleep Function	In Open Loop Mode	No	Yes
Automatic Restart	Time Between Attempts	Not Adjustable	0.0 – 600.0 sec (selectable)
V/Hz Patterns	Qty.	1 Preset, 1 Custom	15 Preset, 2 Custom
Skip Frequencies	Qty.	2	3
Custom Drive Software	Embedded	No	Flash memory
Parameter Upload/Download	PC Software	InverterWin	Drive Wizard Software
Accel/Decel Time	Sec.	0.0 - 3600.0 sec	0.1 - 6000.0 sec.
Closed Loop PID Control	Analog Input Filter	No	Yes
	Two Feedback	No	Yes
DC Injection Function	At Start/At Stop	At Start/At Stop	At Start/At Stop (adjustable) +HSB during stop
Braking Function	DB Transistor	Built-in to 10HP (VT-230V) Built-in to 25HP (VT-460V)	Built-in to 25HP
	Special	No	High Slip Braking all models (Faster stopping without options)
Cooling Fan	On/Off Control	Power-up based	Run Based
	Service	Disassembly required	Modular/pluggable fan select models
	Operating Hours	Drive power-up hours logged	Logged
Timer Function	On/Off Delay	On/Off Delay (0-25.5 sec)	On Delay at start (0-600 sec) On/Off Delay Timer (0-3000sec)

Product Transition Guide GPD506/P5 to P7

GPD506/P5 to P7 Specification Differences (continued)

Feature or Function	Item	Yaskawa GPD506/P5	Yaskawa P7
Design Features (continued)			
Common DC Bus Capable	-	No	Yes
DC Link or AC Choke	-	230V: 30HP to 125HP (VT) 460V: 30 to 250HP (VT)	DC Link (Standard) 240V: 30HP to 150 HP 480V: 40 HP to 500 HP
Harmonic Counter Measures	-	12 Pulse: 230V: 30HP and Above 460V: 30HP to 250HP	12 Pulse: 240V: 30HP to 150HP 480V: 40HP to 500HP
Unique Feature/Function	-	-	HSB – High Slip Braking
Inputs and Outputs			
Digital Input Terminal	Total Qty.	6	7 (optically isolated)
	NPN/PNP	NPN	Switchable NPN/PNP
Digital Output Terminal	Total Qty	2	3
	Relay Output	1 x Form C, 1 x Form A,	2 x Form A, 1 x Form C
Analog Input	Qty.	2	2
	Level Input	0-10V or 4-20mA	0-10 or 4-20mA
	Scan Rate	5 msec	5 msec
	Loss Detection	Ramp or Continue	Ramp, Coast or Continue
Analog Output	Qty.	1	2
	Output Level	0-10V	0-10V or 4-20ma With independent level selections
	Resolution	9 bit	10 bit plus sign
Service Conditions			
Rated Input	-	3-phase, 200-230Vac 3-phase, 380-460Vac Tolerance +10 to -15% 3-phase,500-600Vac Tolerance +10 to -10% Frequency: 50/60 Hz +/- 5%	3-phase, 200-240Vac 3-phase, 380-480Vac Tolerance +10 to -15% Frequency: 50/60 Hz +/- 5% Note: P7 Models 2037-2110 rated for 200-230Vac.
Ambient Temperature	°C	(IP21/NEMA1) -10°C ~ +40°C (IP00/Protected Chassis) -10°C ~ +45°C	-10°C ~ +40°C (IP21/NEMA1) -10°C ~ +45°C (IP00/Protected Chassis) (Automatic OL protection curve based on ambient temperature setting of L8-12)
Storage Temperature	°C	-10°C ~ +60°C	-20°C ~ +60°C
Enclosure Types	NEMA 4X	Optional	N/A
	NEMA 3/3R	Optional	N/A

Product Transition Guide

GPD506/P5 to P7

Digital Operator Comparison

- Enhanced LCD operator with built-in copy function and parameter verify for P7
- Optional LED operator available for P7
- LCD contrast adjustment
- Simplified parameter grouping for easier navigation and set-up

GPD506/P5 Operator

LCD DISPLAY

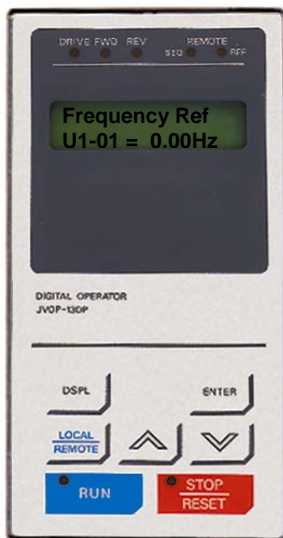

New P7 Operator

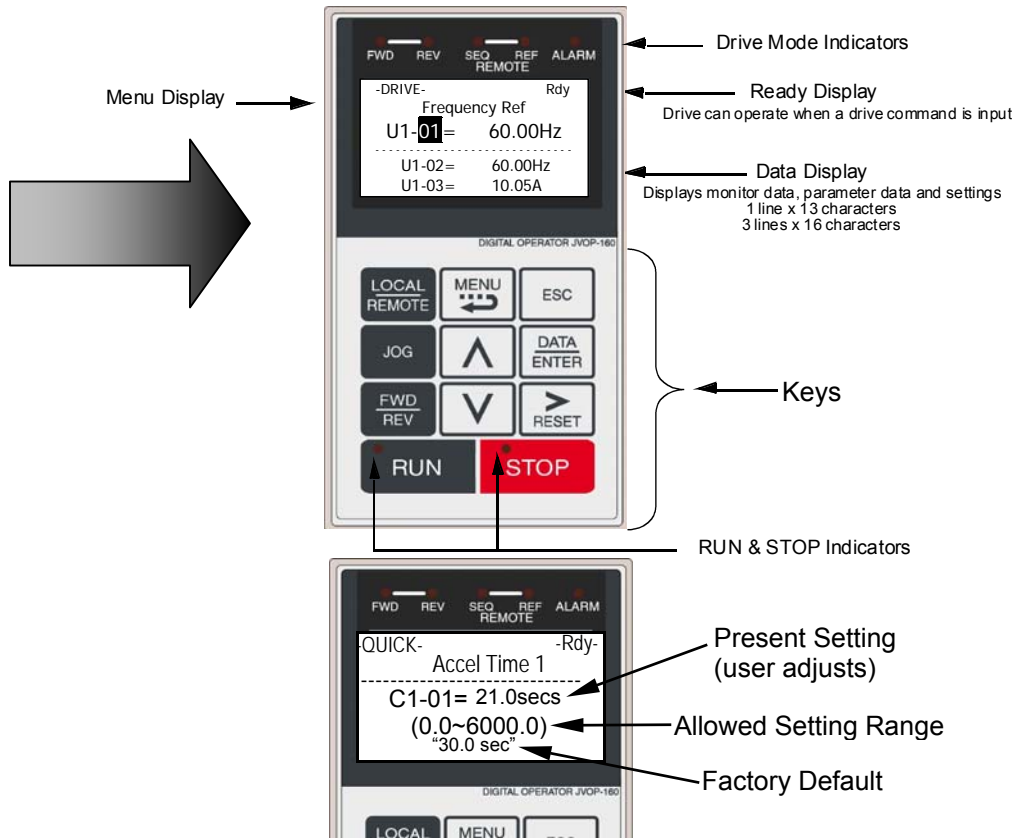

- P7 copy keypad is capable of uploading all of the parameter settings from the P7 drive memory.
 - Upload of GPD506/P5 parameters to P7 not possible at this time
 - P7 Drives must have the same software version, model, and control mode to copy parameters.
- A Quick Start menu is added to aid in simple start-ups.
- The Quick Start menu consists of 64 parameters. The Advanced menu is the other menu choice.

Simplified Menu Structure in P7:

GPD506/P5	P7
--	Operation "DRIVE"
Quick Start -- 16 Parameters	Quick Setting "QUICK"
Programming (All Parameters)	Programming "ADV"
--	Modified Constants "VERIFY"
--	Auto-Tuning "A.TUNE"
--	

GPD506/P5 to P7 Terminal Comparison

The factory default is 2-wire control as shown.

GPD506/P5 Terminal			P7 Terminal (Designations similar to GPD506/P5)		
Type	GPD506/P5 Terminal	Default Function & Description	P7 Terminal	Default Function	P7 Description
Digital Input Signals	S1	Forward run/stop, Forward run when closed, and stop when open. Photo-coupler insulation Input: +24VDC 8mA	S1	Forward run/stop command	–
	S2	Reverse run/stop, Reverse run when closed, Stop when open. Multi-function contact input (n036) Photo-coupler insulation Input: +24VDC 8mA	S2	Reverse run/stop command	–
	S3	External fault input, Fault when closed, normal state when open. Multi-function contact input (n037) Photo-coupler insulation Input: +24VDC 8mA	S3	External fault input	
	S4	Fault reset input, Reset when closed. Multi-function contact input (n038) Photo-coupler insulation Input: +24VDC 8mA	S4	Fault reset	Multi-function digital inputs. Functions set by: H1-01 to H1-05. 24 VDC, 8mA Photo coupler isolation
	S5	Multi-step speed reference 1, Enabled when closed. Multi-function contact input (n039) Photo-coupler insulation Input: +24VDC 8mA	S5	Multi-step speed reference 1	
	S6	Multi-step speed reference 2, Enabled when closed. Multi-function contact input (n040) Photo-coupler insulation Input: +24VDC 8mA	S6	Multi-step speed reference 2	
	–	–	S7	Jog frequency reference	
	SC	Sequence input common terminal	SN	Digital input common	Factory connected for internal supply sinking mode. Refer to P7 User Manual for other methods.
		–	SC	Factory connected to SP	
		–	SP	Factory connected to SC	

Product Transition Guide

GPD506/P5 to P7

GPD506/P5 Terminal			P7 Terminal (Designations similar to GPD506/P5)		
Type	GPD506/P5 Terminal	Default Function & Description	P7 Terminal	Default Function	P7 Description
Analog Input Signals	FS	+15V Power supply output for analog command (Allowable current, 20mA max.)	+V	+15Vdc power output	+15Vdc (Max. current: 20mA)
	FV	Frequency reference input (voltage) 0 to +10V/100%, <i>n043</i> = "FV=MSTR": FV enabled <i>n043</i> = "FI=MSTR": FI enabled 0 to +10V (20kW)	A1	Analog input or speed command	0 to +10Vdc=100% (20k ohm)
	FI	Frequency reference input (current) 4 to 20mA/100% <i>n043</i> = "FV=MSTR": FV enabled <i>n043</i> = "FI=MSTR": FI enabled 4 to 20mA (250W)	A2	Analog input or speed command	4 to 20mA=100%/(250 ohms) 0 to +10Vdc=100%/(20k ohm) Function set by H3-09.
	FC	Common terminal 0V	AC	Analog common	–
	E(G)	Connection to shield sheath of signal lead	E(G)	Shield wire, optional ground line connection point	–
Digital Output Signals	M1	During running (N.O. contact) Closed when running.	M1	During run (N.O. contact)	Form A Dry contacts capacity: 1 A max. at 250Vac 1 A max. at 30Vdc Multi-function digital output. Function set by H2-01.
	M2	Multi-function contact output (<i>n042</i>) Dry contact capacity: 250VAC 1A or less 30VDC 1A or less			
	–	–	M3	Remote/Auto Operation (N.O. contact)	
	–	–	M4		
	MA	Fault contact output (N.O./N.C. contact) Fault when closed between terminals MA and MC Fault when open between terminals MB and MC	MA	Same function as GPD506/P5. Non-programmable	
	MB		MB		
MC	Multi-function contact output (<i>n041</i>) Dry contact capacity: 250VAC 1A or less 30VDC 1A or less	MC	Form C Dry contacts capacity: 1 A max. at 250Vac 1 A max. at 30Vdc		
Analog Output Signals	AM	Frequency meter output 0 to +10V/100% frequency Multi-function analog monitor 1 (<i>n052</i>) 0 to +10V 2mA or less	FM	Output frequency	0 to +10Vdc 10V=100% Output frequency (Max current 2mA). Function set by H4-01.

Product Transition Guide Terminal Comparison

GPD506/P5 Terminal			P7 Terminal (Designations similar to GPD506/P5)		
Type	GPD506/P5 Terminal	Default Function & Description	P7 Terminal	Default Function	P7 Description
	-	-	AM	Output current	0 to +10Vdc or 10V=100% Drive output current (Max current 2mA) Drive's rated output current / Function set by H4-04.
	AC	Frequency meter output "AM" Common	AC	Analog common	-
RS-485/422	-	-	R+	Modbus communication	-
	-	-	R-	Differential input, PHC isolation	
	-	-	S+	Modbus communication	
	-	-	S-	Differential output, PHC isolation	
	-	-	IG	Signal common	

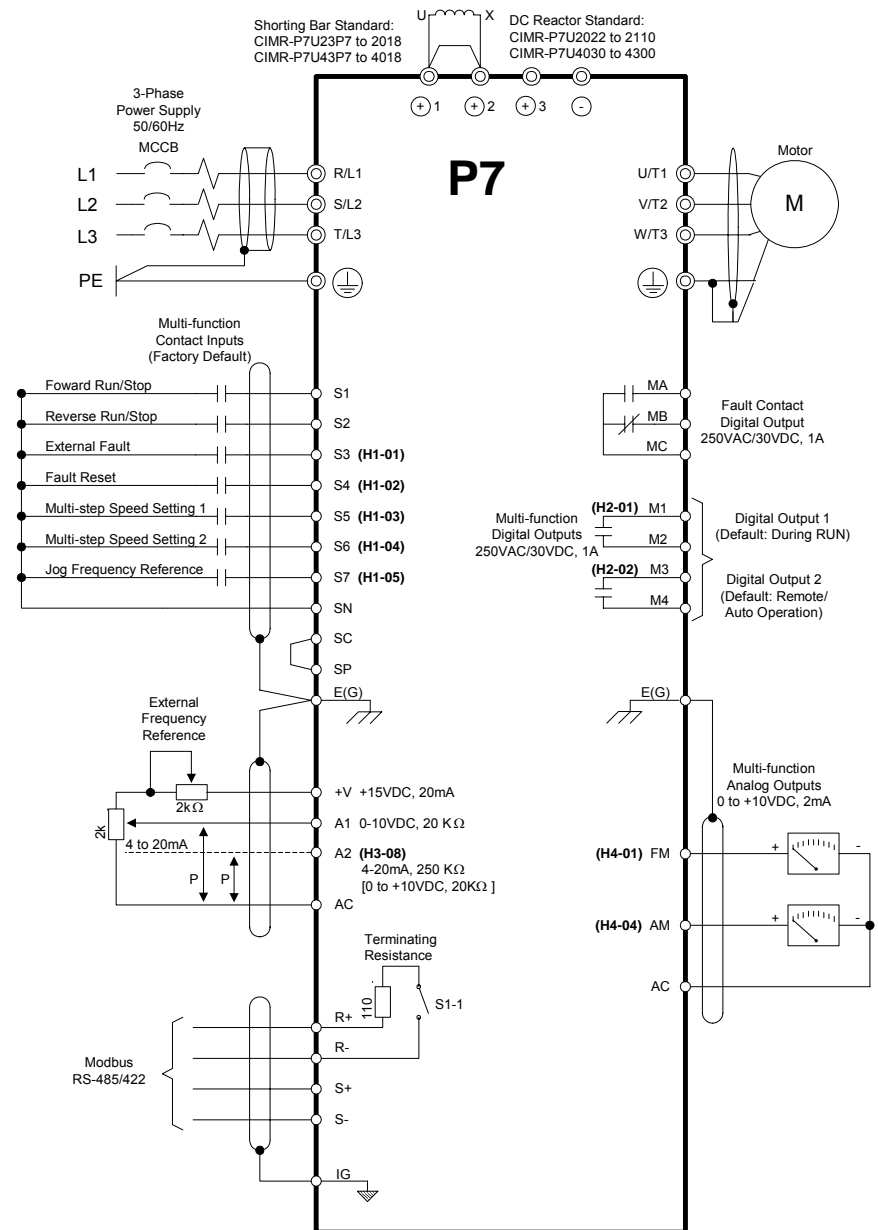
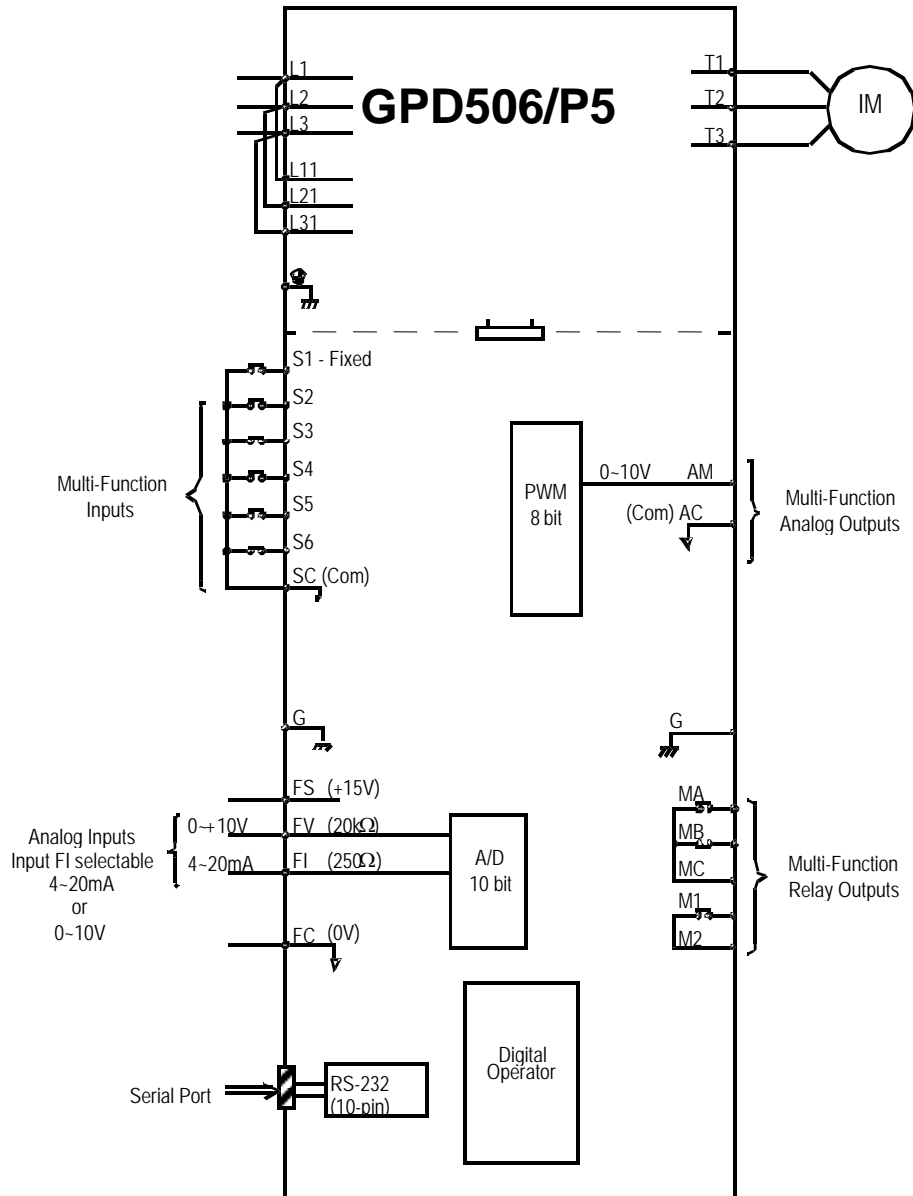

Product Transition Guide

Terminal Comparison



Product Transition Guide GPD506/P5 to P7

Network Communications

GPD506/P5	P7
Not Available	DeviceNet
Not Available	EtherNet
Not Available	Profi-Bus
RS-232 PCB Port (2CN)	RS-232 via Digital Operator Port
SI-K2/P RS-485 Modbus Communication Card 	Standard Built-in RS-485
Lon Works 	Lon Works ²
Johnson Controls MetaSys N2	Not Applicable
FLN Network for System 600/ Apogee	Not Applicable

Software Upload/Download Tool

InverterWin	DriveWizard
-------------	-------------

² Available as an option based on market demands

Network Communications Option Availability

Note: Communication option release schedule is subject to change. Yaskawa Marketing Communications will provide official notice of product availability.

Present



Ready now, available at P7 launch



P7 (CM058) available at P7 launch



Modbus-Plus, testing, available at P7 launch

Ethernet
MODBUS TCP/IP

Available at P7 launch



Ready now, available at P7 launch

Product Transition Guide

GPD506/P5 to P7

Details on New P7 Features & Functions

Note: This section details only a few of the new P7 features.

○ New Auto Tuning

The P7 comes with a Motor Auto-tuning function to help to optimize the drive performance.

Feature	GPD506/P5	P7
R1 Primary Resistance Tuning	No	Yes

R1 Primary Resistance Auto-tuning method is for motor terminal resistance. This method involves no motor shaft rotation.

○ New High Slip Braking

The P7 incorporates a new braking function called High Slip Braking (HSB). By using a method that utilizes increased rotor slip, the drive will gain the capability of stopping up to 50% faster than without a braking resistor. All of this without the need of any external equipment or resistors!

Greater than 150% brake torque is possible.

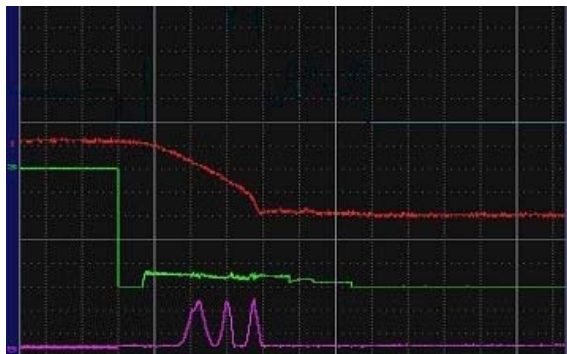

Motor speed
Motor voltage
DC-Bus voltage

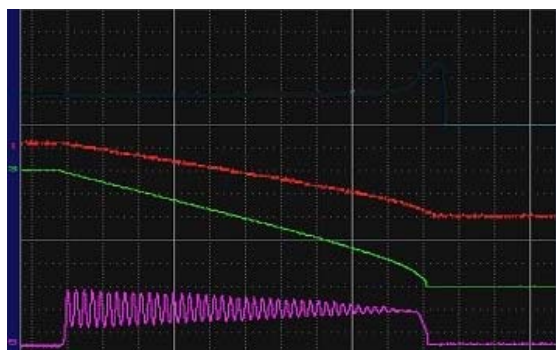

Motor speed
Motor voltage
DC-Bus voltage

Appendix 1
Ratings and Heat Loss Comparison

Product Transition Guide

GPD506/P5 to P7

Page Intentionally Left Blank

Product Transition Guide

Appendix 1 –Ratings and Heat Loss Comparison

NEC HP Ratings for 240V Normal Duty Models

		GPD506/P5 230V Models				P7 240V Models			
		Variable Torque (n116=1)				Normal Duty (C6-01=2)			
NEC HP 230V	NEC Amps	GPD506/P5 Model CIMR-P5U	Output Amps	Fc kHz	Overload% VT 1 minute	P7 Model CIMR-P7U	Output Amps	Fc kHz	Overload % ND 1 minute
5	15.2	23P71	17.5	15	120	23P71	16.8	10	107
7.5	22	25P51	27	10	120	25P51	23	15	120
10	28	27P51	36	10	120	27P51	31	15	102
15	42	20111	54	10	120	20111	46.2	8	117
20	54					20151	59.4	10	117
25	68	20151	68	10	120	20181	74.8	10	114
30	80	20181	80	15	120	20221	88	10	116
40	104	20221	104	15	120	20301	115	10	120
50	130	20301	130	10	120	20371*	162	5	107
60	154	20371*	160	10	120				
75	192	20451*	192	10	120	20451*	192	5	113
						20551*	215	8	120
100	248	20551*	248	8	120	20751*	312	2	109
125	312	20751*	312	8	120				
150	360	-	-	-	-	20901*	360	2	115
150	360	-	-	-	-	21100*	415	2	120

*Note: Optional NEMA1 kit required for NEMA1 rating. Input voltage rating is 230V on these models.

Product Transition Guide

Appendix 1 –Ratings and Heat Loss Comparison

NEC HP Ratings for 480V Normal Duty Models

		GPD506/P5 460V Models				P7 480V Models			
		Variable Torque (n116=1)				Normal Duty (C6-02=2)			
NEC HP 460V	NEC Amps	GPD506/P5 Model CIMR-P5U	Output Amps	Fc kHz	OL % VT 1 minute	P7 Model CIMR-P7U	Output Amps	Fc kHz	Overload % ND 1 minute
5.0	7.6	43P71	8.5	10	120	43P71	7.6	15	120
						44P01	8.7	15	120
7.5	11	44P01	11.7	10	120	45P51	12.5	15	120
10	14	45P51	14.8	10	120	47P51	17	15	120
15	21	47P51	21	10	120	40111	27	8	107
20	27	40111	28.6	10	120				
25	34	40151	34	10	120	40151	34	10	109
30	40	40181	41	10	120	40181	40	10	117
40	52	40221	52	8	120	40301	67.2	8	107
50	65	40301	65	5	120				
60	77	40371	80	5	120	40371	77	8	117
75	96	40451	96	5	120	40451	96	8	114
100	124	40551	128	5	120	40551	125	5	108
125	156	40751*	180	5	120	40751*	156	5	115
150	180					40901*	180	8	120
200	240	41101*	240	5	120	41101*	240	5	108
						41321*	260	5	120
250	302	41601*	302	5	120	41601*	304	5	120
300	361	41850	380	2.5	120	41850	414	2	107
350	414	42200	506	2.5	120				
400	477					42200	506	2	118
450	506								
500	590	43000	675	2.5	120	43000	675	2	120
550	660								

*Note: Optional NEMA1 kit required on these models for NEMA1 rating.

Product Transition Guide

Appendix 1 –Ratings and Heat Loss Comparison

Heat Loss Data

Note: Ampacity ratings vary between GPD506/P5 and P7 models.
Refer to NEC Ratings tables in Appendix 1 for the appropriate GPD506/P5 to P7 cross-reference.

GPD506/ P5 Model	GPD506/P5 (W)		
	Internal	Heatsink	Total
23P7	80	135	215
25P5	90	210	300
27P5	110	235	345
2011	160	425	585
2015	200	525	725
2018	230	655	885
2022	280	830	1110
2030	500	1050	1550
2037	700	1250	1950
2045	750	1550	2300
2055	1000	1950	2950
2075	1300	2300	3600
2090	-		
2110	-		
40P4	50	10	60
40P7	65	20	85
43P7	65	80	145
44P0	80	120	200
45P5	85	135	220
47P5	120	240	360
4011	150	305	455
4015	180	390	570
4018	195	465	660
4022	260	620	880
4030	315	705	1020
4037	370	875	1245
4045	415	970	1385
4055	710	1110	1820
4075	890	1430	2320
4090	-		
4110	1160	1870	3030
4132	-		
4160	1520	2670	4190
4185	1510	3400	4910
4220	2110	4740	6850
4300	2910	6820	9730

P7 Model	P7 (W)		
	Internal	Heatsink	Total
23P7	74	110	184
25P5	84	164	248
27P5	113	219	332
2011	168	357	525
2015	182	416	598
2018	208	472	680
2022	252	583	835
2030	333	883	1216
2037	421	1010	1431
2045	499	1228	1727
2055	619	1588	2207
2075	844	1956	2800
2090	964	2194	3158
2110	1234	2733	3967
40P4	39	14	53
40P7	41	17	58
43P7	68	80	148
44P0	70	90	160
45P5	81	127	208
47P5	114	193	307
4011	158	232	390
4015	169	296	465
4018	201	389	590
4022	233	420	653
4030	297	691	988
4037	332	801	1133
4045	386	901	1287
4055	478	1204	1682
4075	562	1285	1847
4090	673	1614	2287
4110	847	1889	2736
4132	1005	2388	3393
4160	1144	2791	3935
4185	1328	2636	3964
4220	1712	3797	5509
4300	2482	5838	8320

Product Transition Guide
Appendix 1 – Ratings and Heat Loss Comparison

Page Intentionally Left Blank

Appendix 2
Mechanical Dimensions

Product Transition Guide

GPD506/P5 to P7

Page Intentionally Left Blank

Product Transition Guide

Appendix 2 – Mechanical Dimensions

Panel Cut-out for External Heatsink Mounting

Note: Ampacity ratings vary between GPD506/P5 and P7 models.
Refer to NEC Ratings tables in Appendix 1 for the appropriate GPD506/P5 to P7 cross-reference.

GPD506/P5 Panel Cutout for External Heatsink				
Model	GPD506/P5 (mm)		GPD506/P5 (in)	
	W	H	W	H
23P7	138	271	5.43	10.67
25P5	180	298	7.09	11.73
27P5	180	298	7.09	11.73
2011	200	377	7.87	14.84
2015	200	377	7.87	14.84
2018	308	404	12.13	15.91
2022	308	404	12.13	15.91
2030	403	627	15.87	24.69
2037	403	627	15.87	24.69
2045	445	756	17.52	29.76
2055	445	756	17.52	29.76
2075	555	894	21.85	35.20
2090	-			
2110	-			
43P7	138	271	5.43	10.67
45P5	180	298	7.09	11.73
47P5	180	298	7.09	11.73
4011	200	377	7.87	14.84
4015	200	377	7.87	14.84
4018	308	404	12.13	15.91
4022	308	404	12.13	15.91
4030	309	571	12.17	22.48
4037	309	571	12.17	22.48
4045	309	571	12.17	22.48
4055	440	761	17.32	29.96
4075	440	761	17.32	29.96
4090	-			
4110	555	894	21.85	35.20
4132	-			
4160	555	894	21.85	35.20
4185	875	1324	34.45	52.13
4220	875	1324	34.45	52.13
4300	873	1475	34.37	58.07

P7 Panel Cutout for External Heatsink				
Model	P7 (mm)		P7 (in)	
	W	H	W	H
23P7	138	271	5.43	10.67
25P5	138	271	5.43	10.67
27P5	197	298	7.76	11.73
2011	197	298	7.76	11.73
2015	233	353	9.17	13.90
2018	233	353	9.17	13.90
2022	244	369	9.61	14.53
2030	269	419	10.59	16.50
2037	359	545	14.13	21.46
2045	359	545	14.13	21.46
2055	434	673	17.09	26.50
2075	434	673	17.09	26.50
2090	484	782	19.06	30.79
2110	555	817	21.85	32.17
43P7	138	271	5.43	10.67
45P5	138	271	5.43	10.67
47P5	197	298	7.76	11.73
4011	197	298	7.76	11.73
4015	233	353	9.17	13.90
4018	233	353	9.17	13.90
4022	269	419	10.59	16.50
4030	269	419	10.59	16.50
4037	309	519	12.17	20.43
4045	309	519	12.17	20.43
4055	309	519	12.17	20.43
4075	434	673	17.09	26.50
4090	434	673	17.09	26.50
4110	484	782	19.06	30.79
4132	484	782	19.06	30.79
4160	555	817	21.85	32.17
4185	-			
4220	-			
4300	-			

Product Transition Guide

Appendix 2 – Mechanical Dimensions

Mounting Hole Data

Note: Ampacity ratings vary between GPD506/P5 and P7 models.
Refer to NEC Ratings tables in Appendix 1 for the appropriate GPD506/P5 to P7 cross-reference.

GPD506/P5					
Model	Enclosure	(in)		(mm)	
		H1	W1	H1	W1
23P71	NEMA1	10.47	4.96	266	126
25P51	NEMA1	11.22	7.32	285	186
27P51	NEMA1	11.22	7.32	285	186
20111	NEMA1	14.37	9.29	365	236
20151	NEMA1	14.37	9.29	365	236
20181	NEMA1	17.13	10.83	435	275
20221	NEMA1	17.13	10.83	435	275
20301	NEMA1	25.59	12.6	650	320
20371	NEMA1	25.59	12.6	650	320
20451	NEMA1	30.51	14.57	775	370
20551	NEMA1	30.51	14.57	775	370
20751	NEMA1	35.24	17.52	895	445
20900	Open (IP00)	-			
21100	Open (IP00)	-			
43P71	NEMA1	10.47	4.96	266	126
45P51	NEMA1	10.22	7.32	260	186
47P51	NEMA1	10.22	7.32	260	186
40111	NEMA1	14.37	9.29	365	236
40151	NEMA1	14.37	9.29	365	236
40181	NEMA1	17.13	10.83	435	275
40221	NEMA1	17.13	10.83	435	275
40301	NEMA1	24.02	10.83	610	275
40371	NEMA1	24.02	10.83	610	275
40451	NEMA1	24.02	10.83	610	275
40551	NEMA1	31.3	13.78	795	350
40751	NEMA1	31.3	13.78	795	350
40901	NEMA1	-			
41101	NEMA1	35.24	17.52	895	445
41321	NEMA1	35.24	17.52	895	445
41601	NEMA1	35.24	17.52	895	445
41850	Open (IP00)	55.12	29.53	1400	750
42200	Open (IP00)	55.12	29.53	1400	750
43000	Open (IP00)	61.02	29.53	1550	750

P7					
Model	Enclosure	(in)		(mm)	
		H1	W1	H1	W1
23P71	NEMA1	10.47	4.96	266	126
25P51	NEMA1	10.47	4.96	266	126
27P51	NEMA1	11.22	7.32	285	186
20111	NEMA1	11.22	7.32	285	186
20151	NEMA1	13.19	8.5	335	216
20181	NEMA1	13.19	8.5	335	216
20221	NEMA1	15.16	7.68	385	195
20301	NEMA1	17.13	8.66	435	220
20371	NEMA1	22.64	9.84	575	250
20451	NEMA1	22.64	9.84	575	250
20551	NEMA1	27.56	12.8	700	325
20751	NEMA1	27.56	12.8	700	325
20901	NEMA1	32.28	14.57	820	370
21100	Open (IP00)	33.56	17.52	852	445
43P71	NEMA1	10.47	4.96	266	126
45P51	NEMA1	10.47	4.96	266	126
47P51	NEMA1	11.22	7.32	285	186
40111	NEMA1	11.22	7.32	285	186
40151	NEMA1	13.19	8.5	335	216
40181	NEMA1	13.19	8.5	335	216
40221	NEMA1	17.13	8.66	435	220
40301	NEMA1	17.13	8.66	435	220
40371	NEMA1	21.06	10.24	535	260
40451	NEMA1	21.06	10.24	535	260
40551	NEMA1	21.06	10.24	535	260
40751	NEMA1	27.56	12.8	700	325
40901	NEMA1	27.56	12.8	700	325
41101	NEMA1	32.28	14.57	820	370
41321	NEMA1	32.28	14.57	820	370
41601	NEMA1	33.66	17.52	855	445
41850 (1)	Open (IP00)	50	10.63	1270	270
42200 (1)	Open (IP00)	50	10.63	1270	270
43000 (1)	Open (IP00)	56.7	14.37	1440	365

Note (1): 3 mounting holes top and 3 mounting holes bottom.
Dimension is between each mounting hole.

Appendix 3 – Parameter Cross Reference

The following parameter list shows each GPD506/P5 parameter and the P7 equivalent. P7 parameters without a GPD506/P5 equivalent are omitted for brevity. For details on P7 parameters please refer to the P7 manual. Parameters are listed numerically by GPD506/P5.

Appendix 3- Parameter Cross Reference

GPD506/P5 Parameter			P7 Parameter		
Param No. Nxxx	Parameter Name	Description or Selection	Description or Selection	Parameter Name	Param. No.
001	Password	0: Parameter n001 read/write and parameter n002 ~ n116 read only. (Operator's FREF and F/R is read/write. Others are read only, 1: The 1st function (n001 ~ n036) are read/write, others read only 2: The 2nd function (n001 ~ n053) are read/write, others read only 3: The 1st, 2nd, and 3rd functions (n001 ~ n116) are read/write	0: Operation Only 1: User Level (only available if A2 parameters have been set) 2: Advanced Level	Access Level Selection	A1-01
		6: 2-wire initialization (Japanese spec.) 8: Initialization (2wire sequence) 9: Initialization (3wire sequence)	0: No Initialize 1110: User Initialize (The user must first set their own parameter values and then store them using parameter o2-03.) 2220: 2-Wire Initialization 3330: 3-Wire Initialization	Initialize Parameters	A1-03
002	Run Signal Selection	Value-Run Command-----Freq Reference 0: Operator-----Operator 1: Terminal block -----Operator 2: Operator----- Terminal block 3: Terminal block -----Terminal block 4: Operator -----Communication 5: Terminal block -----Communication 6: Communication-----Transmission 7: Communication-----Operator 8: Communication----- Terminal block	0: Operator - Digital preset speed U1-01 or d1-01 to d1-17. 1: Terminals - Analog input terminal A1 (or terminal A2 based on parameter H3 13). 2: Serial Com - Modbus RS-422/485 terminals R+, R-, S+, and S-. 3: Option PCB - Option board connected on 2CN.	Frequency Reference Selection	b1-01
			0: Operator - RUN and STOP keys on Digital Operator. 1: Terminals - Contact closure on terminals S1 or S2. 2: Serial Com - Modbus RS-422/485 terminals R+, R-, S+, and S-. 3: Option PCB - Option board connected on 2CN.	Run Command Selection	b1-02
003	Input voltage	Set unit:0.1V and set ranges:150.0-733.1V	Set to the nominal voltage of the incoming line. Sets the maximum and base voltage used by preset V/F patterns, adjusts the levels of drive protective features (i.e. overvoltage, braking resistor turn-on, stall prevention, etc.).	Input Voltage Setting	E1-01
004	Stop method selection	0: Deceleration stop 1: Coast to stop 2: Coast to stop 1 with timer 3: Coast to stop 2 with timer	0: Ramp to Stop 1: Coast to Stop 2: DC Injection to Stop 3: Coast with Timer (A new run command is ignored if received before the timer expires).	Stopping Method Selection	b1-03
005	Motor Rotation	0: Rotation CCW from load side. 1: Rotation CW from load side	Determines the forward rotation of the motor, and if reverse operation is disabled.	Reverse Operation Selection	b1-04
006	Reverse inhibit	0: Reverse enabled 1: Reverse disabled	0: Reverse Enabled 1: Reverse Disabled 2: Exchange Phase - Change direction of forward motor rotation. 3: ExchgPhs, Rev Dsbl - Change direction of forward motor rotation and disable reverse operation.		
007	Remote/Local key	0: The function of the Remote/Local key is disabled. 1: The function of the Remote/Local key is enabled.	0: Disabled 1: Enabled	Local/Remote Key Function Selection	o2-01
008	Function selection of STOP key	0: The STOP key is effective when run command is from the operator. 1: The STOP key is always enabled.	0: Disabled 1: Enabled	STOP Key Function Selection	o2-02
009	Frequency Reference selection	0: Frequency reference setting by the operator, the 'Enter' input is not required. 1: Frequency reference setting by the operator, the 'Enter' input is required.	0: Disabled - Data/Enter key must be pressed to enter a frequency reference. 1: Enabled - Data/Enter key is not required. The frequency reference is adjusted by the up and down arrow keys on the Digital Operator without having to press the data/enter key.	Frequency Reference Setting Method Selection	o2-05

Appendix 3- Parameter Cross Reference

GPD506/P5 Parameter			P7 Parameter		
Param No. Nxxx	Parameter Name	Description or Selection	Description or Selection	Parameter Name	Param. No.
010	V/f pattern selection	1: Fixed V/f pattern 0: Adjustable V/f pattern (Constant n011-n017 can be set)	There are 15 different preset V/F patterns to select from (E1-03 = 0 to E) with varying voltage profiles, base levels (base level = frequency at which maximum voltage is reached), and maximum frequencies. There are also settings for Custom V/F patterns that will use the settings of parameters E1-04 through E1-13. E1-03 = F selects a custom V/F pattern with an upper voltage limit and E1-03 = FF selects a custom V/F pattern without an upper voltage limit. 0: 50 Hz 1: 60 Hz 2: 60Hz (50 Hz Base) 3: 72 Hz (60 Hz Base) 4: 50 Hz VT1 5: 50 Hz VT2 6: 60 Hz VT1 7: 60 Hz VT2 8: 50 Hz HST1 9: 50 Hz HST2 A: 60 Hz HST1 B: 60 Hz HST2 C: 90 Hz (60Hz Base) D: 120 Hz (60Hz Base) E: 180 Hz (60Hz Base) F: Custom V/F FF: Custom w/o limit	V/F Pattern Selection	E1-03
011	Max. output frequency	Set unit: 0.1Hz and set range: 50.0-400.0Hz	0.0 to 120.0	Maximum Output Frequency	E1-04
012	Maximum voltage	Set unit: 0.1V and set ranges: 0.1-733.1V	0 to 255.0 (240V), 0 to 510.0(480V)	Maximum Output Voltage	E1-05
013	Base Frequency	Set unit: 0.1Hz and set range: 0.2-400.0Hz	0.0 to 200.0	Base Frequency	E1-06
014	Mid Freq output	Set unit: 0.1Hz and set range: 0.1-399.9Hz	0.0 to 200.0	Mid Output Frequency A	E1-07
015	Mid Freq. voltage	Set unit: 0.1V and set ranges: 0.1-733.1V	0 to 255.0 (240V,) 0 to 510.0 (480V)	Mid Output Voltage A	E1-08
016	Min output frequency	Set unit: 0.1Hz and set range: 0.1-10.0Hz	0.0 to 200.0	Minimum Output Frequency	E1-09
017	Min output voltage	Set unit: 0.1V and set ranges: 0.1-143.7V	0 to 255.0 (240V), 0 to 510.0 (480V)	Minimum Output Voltage	E1-10
018	Acceleration time 1	Set unit: 0.1sec (1sec in 1000sec or more) Set range: 0 to 3600sec	0.0 to 6000.0	Acceleration Time 1	C1-01
019	Deceleration time 1	Set unit: 0.1sec (1sec in 1000sec or more) Set range: 0 to 3600sec		Deceleration Time 1	C1-02
020	Acceleration time 2	Set unit: 1sec and set range: 0-255sec		Acceleration Time 2	C1-03
021	Deceleration time 2	Set unit: 1sec and set range: 0-255sec		Deceleration Time 2	C1-04
022	S curve selection	0: No S curve 1 : 0.2sec 2 : 0.5sec 3 : 1.0sec	0.00 to 2.50	S-Curve Characteristic at Accel Start	C2-01
				S-Curve Characteristic at Accel End	C2-02

Appendix 3- Parameter Cross Reference

GPD506/P5 Parameter			P7 Parameter		
Param No. Nxxx	Parameter Name	Description or Selection	Description or Selection	Parameter Name	Param. No.
023	Digital operator display mode	Set range: 0-4999 0: Hz with 0.1Hz 1: % speed with 0.1% 2-39: RPM. $RPM = 120 * \text{freq ref(Hz)} / n023$ (N023 is a motor pole) 40-4999: n23 fourth digit = decimal point n23 1,2,3 digits = 100% freq set value (100% frequency = $xxx * 10$ in case of 4xxx)	<p>Sets the units of the Frequency References (d1-01 to d1-17), the Frequency Reference Monitors (U1-01, U1-02, U1-05), and the Modbus communication frequency reference.</p> <p>0: Hz 1: % (100% = E1-04) 2 to 39: RPM (Enter the number of motorpoles). 40 to 39999: User display.</p> <p> Set the number desired at maximum output frequency. 4 digit number Number of digits from the right of the decimal point</p> <p>Example 1: o1-03 = 12000, will result in frequency reference from 0.0 to 2000 (2000 = Fmax). Example 2: o1-03 = 21234, will result in frequency reference from 0.00 to 1234 (12.34 = Fmax).</p>	Digital Operator Display Selection	o1-03
024	Freq Ref 1	Set unit: Set range by constant n023 setting: 0-9999	0.00 to E1-04 Value Setting units are affected by o1-03	Frequency Reference 1	d1-01
025	Freq Ref 2	Set unit: Set range by constant n023 setting: 0-9999	0.00 to E1-04 Value Frequency reference when multi-function input "Multi-step speed reference 1" is ON. Setting units are affected by o1-03.	Frequency Reference 2	d1-02
026	Freq Ref 3	Set unit: Set range by constant n023 setting: 0-9999	0.00 to E1-04 Value Frequency reference when multi-function input "Multi-step speed reference 2" is ON. Setting units are affected by o1-03.	Frequency Reference 3	d1-03
027	Freq Ref 4	Set unit: Set range by constant n023 setting: 0-9999	0.00 to E1-04 Value Frequency reference when multi-function input "Multi-step speed reference 1,2" is ON. Setting units are affected by o1-03.	Frequency Reference 4	d1-04
030	Jog Ref	Set unit: Set range by constant n023 setting: 0-9999	0.00 to E1-04 Value Frequency reference when: "Jog frequency reference" is selected via multi-function input terminals. "Jog frequency reference" has priority over "multi-step speed reference 1 to 4". d1-17 is also the reference for the JOG key on the Digital Operator, and the multi-function inputs "forward jog" and "reverse jog". Setting units are affected by o1-03.	Jog Frequency Reference	d1-17
031	Output freq upper limit	Set unit: 1% and set range:0-109%	0.0 to 110.0 Determines maximum frequency reference, set as a percentage of maximum output frequency (E1-04). If the frequency reference is above this value, actual Drive speed will be limited to this value. This parameter applies to all frequency reference sources.	Frequency Reference Upper Limit	d2-01
032	Output freq lower limit	Set unit: 1% and set range:0-100%	0.0 to 110.0 Determines minimum frequency reference, set as a percentage of maximum output frequency (E1-04). If frequency reference is below this value, actual Drive speed will be set to this value. This parameter applies to all frequency reference sources.	Frequency Reference Lower Limit	d2-02
033	Rated motor current	Set unit: 0.1A (In 1000A or more, every 1A) Set range:10-200% of drive rated current	Set to the motor nameplate full load current in amperes (A). This value is automatically set during Auto-Tuning.	Motor Rated Current	E2-01
034	Motor protection selection (OL1)	0: Disabled. 1: Standard motor (eight minutes) 2: Standard motor (five minutes) 3: Inverter rated motor (eight minutes) 4: Inverter rated motor (five minutes)	Sets the motor thermal overload protection (OL1) based on the cooling capacity of the motor. 0: Disabled 1: Standard Fan Cooled	Motor Overload Protection Selection	L1-01

Appendix 3- Parameter Cross Reference

GPD506/P5 Parameter			P7 Parameter		
Param No. Nxxx	Parameter Name	Description or Selection	Description or Selection	Parameter Name	Param. No.
035	Cooling fin overheat Stop method selection	0: Deceleration stop (Decelerate by deceleration time 1) 1: Coast to stop (Decelerate by deceleration time 2) 2: Deceleration stop (Decelerate by deceleration time 2) 3: Operation continues (The alarm is displayed, and drive runs at 80% of the freq ref)	Drive Operation upon OH Pre Alarm Detection. 0: Ramp to Stop (Decel Time C1-02). 1: Coast to Stop 2: Fast-Stop (Decel Time = C1-09). 3: Alarm Only *0 to 2 is recognized as fault detection, and 3 is recognized as alarm. (For the fault detection, the fault contact operates.) 4: OH Alarm & Reduce (Continue operation and reduce output frequency by L8-19)	Overheat Pre-Alarm Operation Selection	L8-03
036	Multi-function contact input 1 (terminal S2)	0: REV command (2wire sequence selection) 1: FWD/REV Command (3wire sequence selection) 2: External fault. (N.O contact input) 3: External fault. (N.C contact input) 4: Fault reset 5: LOCAL/REMOTE switch (run and freq ref) 6: Communication/Control circuit terminal switch (run and freq ref) 7: Emergency stop (N.O. contact input) 8: Emergency stop (N.C contact input) 9: FV/FI terminal switch 10: Multistep speed set 1 11: Multistep speed set 2 12: Multistep speed set 3 13: Jog frequency select 14: Accel/decel time switch 15: External base block instruction (N.O.contact input) 16: External base block instruction (N.C contact input) 17: Speed search command from Max frequency 18: Speed search command from set frequency 19: Parameter set enable/disable 20: PID integral value reset 21: PID control disable 22: Timer start command 23: Inverter overheat (blinking display of OH3) 24: Sample/holding of analog reference 25: KEB instruction (N.O. contact) 26: KEB instruction (N.C. contact) 27: Decel/accel prohibit 28: PID input characteristic switchover	-	Terminal S2 is not programmable in P7 : P7 default setting for terminal S2: Reverse run when closed, stopped when open. Initialization parameter A1-03 programs terminals S1 and S2 for 2-Wire or 3-Wire run control.	-
037	Multi-function contact input 2 (terminal S3)	Set range: 2-28 (It is the same as constant n036)	0 to 70 Selects the function of terminal S3. 0: 3-wire control FWD/REV selection for 3-wire sequence 1: Local/Remote Sel Hand/Auto Selection - Closed = Hand, Open = Auto 2: Option/Inv Sel Selects source of speed command and sequence Closed = Option Card, Open = b1-01 & b1-02 3: Multi-Step Ref 1 Closed = speed command from d1-02 or Terminal A2, Open = speed command determined by b1-01 4: Multi-Step Ref 2 Closed = speed command from d1-03 or d1-04 Open speed command determined by b1-01	Multi-Function Digital Input Terminal S3 Function Selection	H1-01

Appendix 3- Parameter Cross Reference

GPD506/P5 Parameter			P7 Parameter		
Param No. Nxxx	Parameter Name	Description or Selection	Description or Selection	Parameter Name	Param. No.
(con't) 037	Multi-function contact input 2 (terminal S3)	Set range: 2-28	6: Jog Freq Ref Closed = speed command from d1-17 Open = speed command determined by b1-01 7: Multi-Acc/Decel 1 Closed = Accel & Decel Ramps determined by C1-03 & C1-04, Open = Accel & Decel Ramps determined by C1-01 & C1-02 8: Ext BaseBlk N.O. Closed = Output transistors forced off, Open = Normal operation 9: Ext BaseBlk N.C. Closed = Normal Operation, Open = Output transistors forced off A: Acc/Dec RampHold Closed = Acceleration suspended and speed held, Open = Normal Operation C: Term A2 Enable Closed = Terminal A2 is active, Open = Terminal A2 is disabled F: Term Not Used Terminal has no effect 10: MOP Increase Closed = Speed Command Increases, Open = Speed Command Held. Must be set in conjunction with MOP Decrease and b1-02 must be set to 1. 11: MOP Decrease Closed = Speed Command Decreases, Open = Speed Command Held. Must be set in conjunction with MOP Increase and b1-02 must be set to 1. 12: Forward Jog Closed = drive runs forward at speed command entered into parameter d1-17. 13: Reverse Jog Closed = drive runs in reverse at speed command entered into parameter d1-17. 14: Fault Reset Closed = Resets the drive after the fault and the run command have been removed. 15: Fast-Stop N.O. Closed = Drive decelerates using C1-09, regardless of run command status. 17: Fast-Stop N.C. Closed = Normal operation Open = Drive decelerates using C1-09, regardless of run command status. Closed = Normal operation Open = Drive decelerates using C1-09, regardless of run command status. 18: Timer Function Input for independent timer, controlled by b4-01 and b4-02. Used in conjunction with a multi-function digital output. 19: PI Disable Turns off the PI controller, and PI setpoint becomes speed command. 1B: Program Lockout Closed = All parameter settings can be changed.	Multi-Function Digital Input Terminal S3 Function Selection	H1-01

Appendix 3- Parameter Cross Reference

GPD506/P5 Parameter			P7 Parameter		
Param No. Nxxx	Parameter Name	Description or Selection	Description or Selection	Parameter Name	Param. No.
(con't) 037	Multi-function contact input 2 (terminal S3)	Set range: 2-28 (It is the same as constant n036)	Open = Only speed command at U1-01 can be changed. 1C: TrimCtl Increase Closed = Increase motor speed by value in d4-02. Open = Return to normal speed command. Not effective when using d1-01 thru d1-04 as a speed command. Must be used in conjunction with Trim Ctrl Decrease. 1D: Trim Ctl Decrease Closed = Decrease motor speed by value in d4-02 Open = Return to normal speed command. Not effective when using d1-01 thru d1-04 as speed command. Must be used in conjunction with Trim Ctrl Increase. 1E: Ref Sample Hold Analog speed command is sampled then held at time of input closure. 20: External fault, Normally Open, Always Detected, Ramp To Stop 21: External fault, Normally Closed, Always Detected, Ramp To Stop 22: External fault, Normally Open, During Run, Ramp To Stop 23: External fault, Normally Closed, During Run, Ramp To Stop 24: External fault, Normally Open, Always Detected, Coast To Stop 25: External fault, Normally Closed, Always Detected, Coast To Stop 26: External fault, Normally Open, During Run, Coast To Stop 27: External fault, Normally Closed, During Run, Coast To Stop 28: External fault, Normally Open, Always Detected, Fast-Stop 29: External fault, Normally Open, Always Detected, Fast-Stop 2A: External fault, Normally Open, During Run, Fast-Stop 2B: External fault, Normally Closed, During Run, Fast-Stop 2C: External fault, Normally Open, Always Detected, Alarm Only 2D: External fault, Normally Closed, Always Detected, Alarm Only 2E: External fault, Normally Open, During Run, Alarm Only 2F: External fault, Normally Closed, During Run, Alarm Only 30: PI Integral Reset Resets the PI Integral component to zero when closed 31: PI Integral Hold Holds the PI integral value when closed 34: PI SFS Cancel (SFS= SoftStart, also called Accel/Decel, See Parameter b5-17) 35: PI Input Level Sel Inverts the PI error signal when closed 36: Option/Inv Sel 2 Selects source of speed command and sequence Closed = b1-01 & b1-02, Open = Option Card	Multi-Function Digital Input Terminal S3 Function Selection	H1-01

Appendix 3- Parameter Cross Reference

GPD506/P5 Parameter			P7 Parameter		
Param No. Nxxx	Parameter Name	Description or Selection	Description or Selection	Parameter Name	Param. No.
(con't) 037	Multi-function contact input 2 (terminal S3)	Set range: 2-28 (It is the same as constant n036)	60: Motor Preheat Applies current to create heat to avoid condensation Closed = Apply amount of current as set in parameter b2-09 61: Speed Search 1 When closed as a run command is given, drive does a speed search starting at maximum frequency (E1-04). 62: Speed Search 2 When closed as a run command is given, drive does a speed search starting at speed command. 64: Speed Search 3 When opened, the Drive performs a baseblock (motor coasts). When closed, the Drive performs Speed Search from set frequency. 67: Com Test Mode - Used to test RS-485/422 interface. 68: High Slip Braking - Closed = Drive stops using High Slip Braking regardless of run command status. 69: Jog2 - Closed = Drive runs at speed command entered into parameter d1-17. Direction determined by fwd/rev input. 3-wire control Only. 6A: Drive Enable - Closed = Drive will accept run command. Open = Drive will not run. If running, drive will stop per b1-03. Run Command must be cycled 6B: Com/Inv Sel - Selects source of Speed Command and Sequence. Closed = Serial Communication (R+,R-,S+,S-), Open = b1-01 & b1-02 6C: Com/Inv Sel 2 - Selects source of Speed Command and Sequence. Closed = b1-01 & b1-02, Open = Serial Communication (R+,R-,S+,S-) 6D: Auto Mode Sel - Hand/Auto Selection - Closed = Auto, Open = Hand 6E: Hand Mode Sel - Hand/Auto Selection - Closed = Hand, Open = Auto 70: Drv Enbl. Same as 6A except a run command is accepted	Multi-Function Digital Input Terminal S3 Function Selection	H1-01
038	Multi-function contact input 3 (terminal S4)	Set range: 2-28 (It is the same as constant n036)	0-70 Same selections as H1-01	Multi-Function Digital Input Terminal S4 Function Selection	H1-02
039	Multi-function contact input 4 (terminal S5)	Set range: 2-28 (It is the same as constant n036)	0-70 Same selections as H1-01	Multi-Function Digital Input Terminal S5 Function Selection	H1-03
040	Multi-function contact input 5 (terminal S6)	Set range: 2-29	0-70 Same selections as H1-01	Multi-Function Digital Input Terminal S6 Function Selection	H1-04

Appendix 3- Parameter Cross Reference

GPD506/P5 Parameter			P7 Parameter		
Param No. Nxxx	Parameter Name	Description or Selection	Description or Selection	Parameter Name	Param. No.
041	Multi-function contact output 1 (terminal MA-MB-MC)	0: Fault 1: During run. 2: Frequency agree 3: At set frequency agree 4: Freq detect (output freq = set freq detection level) 5: Freq detect (output frequency = set freq detect level) 6: Overtorque detect. (N.O contact) 7: Overtorque detect. (N.C contact) 8: The base block. 9: Operation mode 10: Inverter drive ready 11: Timer function 12: Auto restart. (Fault retry) 13: OL pre-alarm (OL1,OL2) 14: Frequency reference loss 15: Closed from serial communication. 16: PID feedback loss 17: OH1 alarm	Selects the function of terminals M1 to M4. 0: During RUN 1 = Closed when a run command is input or the drive is outputting voltage. 1: Zero Speed = Closed when drive output frequency is less than Fmin (E1-09) 2: Fref/Fout Agree 1 = Closed when drive output speed equals the speed command within the bandwidth of L4-02. 3: Fref/Set Agree 1 = Closed when the drive output speed and the speed command are equal to the value in L4-01 within the bandwidth of L4-02. 4: Freq Detect 1 = Closed when the drive output speed is less than or equal to the value in L4-01, with hysteresis determined by L4-02. 5: Freq Detect 2 = Closed when the drive output speed is greater than or equal to the value in L4-01, with hysteresis determined by L4-02. 6: Inverter Ready = Closed when the drive is not in a fault state, and not in program mode. 7: DC Bus Undervolt = Closed when the DC bus voltage falls below the UV trip level (L2-05) 8: Base Blk 1 = Closed when the drive is not outputting voltage. 9: Operator Reference = Closed when the speed command is coming from the digital operator. A: Remote/Auto Oper = Closed when the run command is coming from the digital operator. B: Trq Det 1 N.O. - Closes when the output current exceeds the value set in parameter L6-02 for more time than is set in parameter L6-03. C: Loss of Ref - Closes when the drive has detected a loss of analog speed command. Speed command is considered lost when it drops 90% in 0.4 seconds. Parameter L4-05 determines drive reaction to a loss of speed command. E: Fault - Closes when the drive experiences a major fault. F: Not Used 10: Minor Fault - Closes when drive experiences a minor fault or alarm. 11: Reset Cmd Active - Closes when the drive receives a reset command from terminals or serial comms. 12: Timer Output - Output for independent timer, controlled by b4-01 and b4-02. Used in conjunction with a multi-function digital input. 17: Trq. Det 1 N.C. - Opens when the output current exceeds the value set in parameter L6-02 for more time than is set in parameter L6-03.	Terminal M3-M4 Function Selection	H2-01

Appendix 3- Parameter Cross Reference

GPD506/P5 Parameter			P7 Parameter		
Param No. Nxxx	Parameter Name	Description or Selection	Description or Selection	Parameter Name	Param. No.
(con't) 041	Multi-function contact output 1 (terminal MA-MB-MC)		1A: Reverse Dir - Closes when the drive is running in the reverse direction. 1E: Restart Enabled - Closes when the drive is performing an automatic restart. Automatic restart is configured by parameter L5-01. 1F: Overload (OL1) - Closes before a motor overload occurs. (90% of OL1 time) 20: OH Prealarm - Closes when the Drive's heatsink temperature exceeds the setting of parameter L8-02. 38: Drive Enable - Closes when the drive enable input is active. 39: Waiting to Run - Closes during the time after a run command is issued, but the Drive is not running due to the time set in parameter b1-10. 3A: OH Freq Reduce 3B: Run Src Com/Opt		H2-01

Appendix 3- Parameter Cross Reference

GPD506/P5 Parameter			P7 Parameter		
Param No. Nxxx	Parameter Name	Description or Selection	Description or Selection	Parameter Name	Param. No.
042	Multi-function contact output 2 (terminal M1-M2)	It is the same as constant n041.	Same selections as H2-01	Terminal M3-M4 Function Selection	H2-02
044	Terminal FI signal Level Selection	0: The FI terminal inputs 0-10V. (Jumper J1 is cut) 1: The FI terminal inputs 4-20mA.	Selects the signal level of terminal A2. 0: 0 to 10Vdc (switch S1-2 must be in the OFF position). 2: 4 to 20mA (switch S1-2 must be in the ON position)	Terminal A2 Signal Level Selection	H3-08
045	Frequency Reference Retention	1: The holding frequency reference is not memorized. 0: The holding frequency reference is memorized and stored in n024	This parameter is used to retain the held frequency reference in U1-01 (d1-01) when power is removed. This function is available when the multi-function inputs "accel/decel ramp hold" or "up/down" commands are selected (H1-XX = A or 10 and 11). 0: Disabled 1: Enabled	MOP Ref Memory	d4-01
046	Frequency Ref Loss selection	0: No detection 1: Continue running at n047 setting	The frequency reference is considered lost when reference drops 90% or more of its current value in less than 400ms. 0: Normal Operation - Drive will run at the frequency reference. 1: Run at L4-06 PrevRef - Drive will run at the percentage set in L4-06 of the frequency reference level at the time frequency reference was lost.	Frequency Reference Loss Detection Selection	L4-05
047	Frequency Ref when frequency reference is lost	Set unit: 1% and set range: 0-100%	0 to 100.0 If the frequency reference loss function is enabled (L4-05=1) and frequency reference is lost, the Drive will run at a reduced frequency reference determined by the following formula: Fref=Fref at time of loss * L4-06.	Frequency Reference Level at Loss Frequency	L4-06
048	Terminal FV gain	Set unit: 1% and set range: 0 to 200%	0.0 to 1000.0 Sets the output level when 10V is input, as a percentage of the maximum output frequency (E1-04).	Terminal A1 Gain Setting	H3-02
049	Terminal FV bias	Set unit: 1% and set range = -100 to +100%	-100.0 to +100.0 Sets the output level when 0V is input, as a percentage of the maximum output frequency (E1-04).	Terminal A1 Bias Setting	H3-03
050	Terminal FI gain	Set unit: 1% and set range: 0 to 200%	0.0 to 1000.0 Sets the output level when 10V is input.	Terminal A2 Gain Setting	H3-10
051	Terminal FI bias	Set unit: 1% and set range -100 to +100%	-100.0 to +100.0 Sets the output level when 0V is input.	Terminal A2 Bias Setting	H3-11
052	Analog output Select (terminal AM-AC)	0: Output frequency (10V = Max frequency n011) 1: Output current (10V = rated current of inverter) 2: Output power (10V = inverter rated power) 3: DC bus voltage (10V = 1150VDC)	Selects which monitor will be output on terminals FM and FC. 1: Frequency Ref (100% = max. output frequency) 2: Output Freq (100% = max. output frequency) 3: Output Current (100% = drive rated current) 6: Output Voltage (100% = 230V or 100% = 460V) 7: DC Bus Voltage (100% = 400V or 100% = 800V) 8: Output kWatts (100% = drive rated power) 15: Term A1 Level 16: Term A2 Level 18: Mot SEC Current (100% = Motor rated secondary current) 20: SFS Output (100% = max. output frequency) 24: PI Feedback	Terminal FM Monitor Selection	H4-01

Appendix 3- Parameter Cross Reference

GPD506/P5 Parameter			P7 Parameter		
Param No. Nxxx	Parameter Name	Description or Selection	Description or Selection	Parameter Name	Param. No.
(cont) 052	Analog output Select (terminal AM-AC)		31: Not Used 36: PI Input 37: PI Output (100% = max. output frequency) 38: PI Setpoint 51: Auto Mode Fref (100% = max. output frequency) 52: Hand Mode Fref (100% = max. output frequency) 53: PI Feedback 2 NOTE: 100% = 10V DC output * FM gain setting (H4-02).	Terminal FM Monitor Selection	H4-01
053	Analog output gain	Set unit: 0.01 and set range: 0.01-2.00	0.0 to 1000.0 Sets terminal FM output voltage (in percent of 10V) when selected monitor is at 100% output.	Terminal FM Gain Setting	H4-02
054	Carrier frequency	1, 2, 4 ~ 6: carrier freq = set value * 2.5 Khz 3: Carrier frequency =8kHz 7, 8, 9: The output freq of 2.5kHz or less is proportional to the carrier frequency. (7: 12*fout ,8: 24*fout, 9:36*fout) 10: Carrier frequency =7kHz (Only 400V 45kW)	Carrier frequency sets the number of pulses per second of the output voltage waveform. 0: Low Noise (Carrier frequency is randomly modulated for lower audible noise) 1: Fc = 2.0 kHz 2: Fc = 5.0 kHz 3: Fc = 8.0 kHz 4: Fc = 10.0 kHz 5: Fc = 12.5 kHz 6: Fc = 15.0 kHz F: Program (Determined by the settings of C6-03 thru C6-05)	Carrier Frequency Selection	C6-02
			0.4 to 15.0 kHz	Carrier Frequency Upper Limit	C6-03
			0.4 to 15.0 kHz	Carrier Frequency Lower Limit	C6-04
			0 to 99	Carrier Frequency Proportional Gain	C6-05
055	Operation after momentary power loss	0: Not Provided. 1: Operation continues after power recovery within 2 sec 2: Operation continues while control power is on (UV1, UV3 faults not are detected)	Enables and disables the momentary power loss function. 0: Disabled - Drive trips on (UV1) fault when power is lost. 1: Power Loss Ride Thru Time - Drive will restart if power returns within the time set in L2-02.* 2: CPU Power Active - Drive will restart if power returns prior to control power supply shut down.* * In order for a restart to occur, the run command must be maintained throughout the ride thru period.	Momentary Power Loss Detection Selection	L2-01
056	Speed search operation level	Set unit: 1% Set range: 0-200% (100%= rated current of inverter)	0 to 200 Used only when b3-01 = 2 or 3. Sets the speed search operation current as a percentage of Drive rated current.	Speed Search Deactivation Current	b3-02
057	Minimum base block time	Set unit: 0.1sec Set range: 0.5-10.0sec	0.1 to 5.0sec Sets the minimum time to wait to allow the residual motor voltage to decay before the Drive output turns back on during power loss ride thru. After a power loss, if L2-03 is greater than L2-02, operation resumes after the time set in L2-03.	Momentary Power Loss Minimum Base Block Time	L2-03

Appendix 3- Parameter Cross Reference

GPD506/P5 Parameter			P7 Parameter		
Param No. Nxxx	Parameter Name	Description or Selection	Description or Selection	Parameter Name	Param. No.
059	Power ride through time	Set unit: 0.1sec and set range: 0.0-2.0sec	0.0 to 25.5sec Sets the power loss ride-thru time. This value is dependent on the capacity of the Drive. Only effective when L2-01 = 1.	Momentary Power Loss Ride-thru Time	L2-02
060	No. of Fault Retries	Setting unit = 1 times Set range: 0-10 times (There is no fault retry at 0)	0 to 10 Sets the counter for the number of times the Drive will perform an automatic restart on the following faults: GF, LF, OC, OV, PF, PUF, RH, RR, OL1, OL2, OL3, OL4, UV1. Auto restart will check to see if the fault has cleared every 5ms. When no fault is present, the Drive will attempt an auto restart. If the Drive faults after an auto restart attempt, the counter is incremented. When the drive operates without fault for 10 minutes, the counter will reset to the value set in L5-01	Number of Auto Restart Attempts	L5-01
061	Fault contact during fault retry	0: Fault contact output enabled while fault retry. 1: Fault contact output disabled while fault retry.	Determines if the fault contact activates during an automatic restart attempt. 0: No Fault Relay - fault contact will not activate during an automatic restart attempt. 1: Fault Relay Active - fault contact will activate during an automatic restart attempt.	Auto Restart Operation Selection	L5-02
062	Jump frequency 1	Set unit: 0.1Hz and set range: 0.0-400.0Hz	0.0 to 200.0 These parameters allow programming of up to three prohibited frequency reference points for eliminating problems with resonant vibration of the motor / machine. This feature does not actually eliminate the selected frequency values, but will accelerate and decelerate the motor through the prohibited bandwidth.	Jump Frequency 1	d3-01
063	Jump frequency 2	Set unit: 0.1Hz and set range: 0.0-400.0Hz		Jump Frequency 2	d3-02
064	Width of jump	Set unit: 0.1Hz and set range: 0.0-25.5Hz		Jump Frequency Width	d3-04
065	Elapsed timer 1 mode	0: Operation time accumulates. 1: Operation time accumulates. (During Run)	Sets how time is accumulated for the elapsed operation timer U1-13. 0: Power-On Time - Time accumulates when the Drive is powered. 1: Running Time - Time accumulates only when the Drive is running.	Cumulative Operation Time Selection	o2-08
066	Elapsed timer 1 (lower 4 digits)	Setting unit = 1 hour, range = 0 ~ 9999 hours 1 minute is stored in EEPROM, < 1day rounded up	0 to 65535 Sets the initial value of the elapsed operation timer U1-13.	Cumulative Operation Time Setting	o2-07
067	Elapsed timer 1 (upper 4 digits)	Set unit: 1(For 10000 hours) and a set range: 0-27. * Initial value becomes 0 only when initialized during CPF4 occurrence.			
068	DC injection braking current	Set unit: 1% Set range: 0-100% (100%= rated current of inverter)	0 to 100 Sets the DC injection braking current as a percentage of the Drive rated current.	DC Injection Braking Current	b2-02
069	DC braking time at stop	Set unit:0.1sec and set range: 0.0-10.0sec	0.00 to 10.00 Sets the time length of DC injection braking at stop in units of 0.01 seconds. NOTE: When b1-03 = 2, actual DC Injection time is calculated as follows: b2-04 * 10 * Output Frequency / E1-04. NOTE: When b1-03 = 0, this parameter determines the amount of time DC Injection is applied to the motor at the end of the decel ramp. NOTE: This should be set to a minimum of 0.50 seconds when using HSB. This will activate DC injection during the final portion of HSB and help ensure that the motor stops completely.	DC Injection Braking Time at Stop	b2-04
070	DC braking time at start	Set unit: 0.1sec and set range: 0.0-10.0sec	0.00 to 10.00 Sets the time of DC injection braking at start in units of 0.01 seconds.	DC Injection Braking Time at Start	b2-03

Appendix 3- Parameter Cross Reference

GPD506/P5 Parameter			P7 Parameter		
Param No. Nxxx	Parameter Name	Description or Selection	Description or Selection	Parameter Name	Param. No.
071	Torque comp gain	Set unit: 0.1 and set range: 0.0-3.0	0.00 to 2.50 This parameter sets the gain for the Drive's automatic torque boost function to match the Drive's output voltage to the motor load. This parameter helps to produce better starting torque. It determines the amount of torque or voltage boost based upon motor current, motor resistance, and output frequency.	Torque Compensation Gain	C4-01
072	Stall prevention during deceleration	0: Stall prevention function none at deceleration 1: The stall prevention is provided while decelerating.	When using a braking resistor, use setting "0". Setting "3" is used in specific applications. 0: Disabled - The Drive decelerates at the active deceleration rate. If the load is too large or the deceleration time is too short, an OV fault may occur. 1: General Purpose - The Drive decelerates at the active deceleration rate, but if the main circuit DC bus voltage reaches the stall prevention level (380/760Vdc), deceleration will stop. Deceleration will continue once the DC bus level drops below the stall prevention level. 2: Intelligent - The active deceleration rate is ignored and the Drive decelerates as fast as possible w/o hitting OV fault level. Range: C1-02 / 10. 3: Stall Prevention w/ Braking Resistor	Stall Prevention Selection During Decel	L3-04
073	Stall prevention level during acceleration	Set unit: 1% Set range: 30-200% (100%= rated current of inverter) (Stall prevention disabled when set point =200%)	Selects the stall prevention method used to prevent excessive current during acceleration. 0: Disabled - Motor accelerates at active acceleration rate. The motor may stall if load is too heavy or accel time is too short. 1: General Purpose - When output current exceeds L3-02 level, acceleration stops. Acceleration will continue when the output current level falls below the L3-02 level. 2: Intelligent - The active acceleration rate is ignored. Acceleration is completed in the shortest amount of time without exceeding the current value set in L3-02.	Stall Prevention Selection During Accel	L3-01
			0 to 200 This function is enabled when L3-01 is "1" or "2". Drive rated current is 100%. Decrease the set value if stalling or excessive current occurs with factory setting.	Stall Prevention Level During Accel	L3-02
074	Stall prevention level during run	Set unit: 1% Set range: 30-200% (100%= rated current of inverter) (Stall prevention disabled when set point =200%)	Selects the stall prevention method to use to prevent Drive faults during run. 0: Disabled - Drive runs a set frequency. A heavy load may cause the Drive to trip on an OC or OL fault. 1: Decel Time 1 - In order to avoid stalling during heavy loading, the Drive will decelerate at Decel time 1 (C1-02) if the output current exceeds the level set by L3-06. Once the current level drops below the L3-06 level, the Drive will accelerate back to its frequency reference at the active acceleration rate. 2: Decel Time 2 - Same as setting 1 except the Drive decelerates at Decel Time 2 (C1-04). When output frequency is 6Hz or less, stall prevention during running is disabled regardless of L3-05 setting.	Stall Prevention Selection During Run	L3-05

Appendix 3- Parameter Cross Reference

GPD506/P5 Parameter			P7 Parameter		
Param No. Nxxx	Parameter Name	Description or Selection	Description or Selection	Parameter Name	Param. No.
075	Set frequency detection level	Set unit: 0.1Hz and set range: 0.0-400.0Hz	0.0 to 200.0 L4-01 and L4-02 are used in conjunction with the multi-function outputs, (H2-01 and H2-02) as a setpoint and hysteresis for a contact closure.	Speed Agreement Detection Level	L4-01
076	Width of frequency agreement detection	Set unit: 0.1Hz and set range: 0.0-25.5Hz	0.0 to 20.0	Speed Agreement Detection Width	L4-02
077	Overtorque/Undertorque Selection	0: Overtorque/undertorque detection disabled. 1: Overtorque is detected during constant speed operation and operation continues after overtorque detection. 2: Overtorque is always detected and operation continues after overtorque detection. 3: Overtorque is detected during constant speed operation and inverter output is disabled after overtorque detection. 4: Overtorque is always detected and inverter output is disabled after overtorque detection. 5: Undertorque is detected during constant speed operation and operation continues after undertorque detection. 6: Undertorque is always detected and operation continues after undertorque detection. 7: Undertorque is detected during constant speed operation and inverter output is disabled after undertorque detection. 8: Undertorque is always detected and inverter output is disabled after undertorque detection.	Determines the drive's response to an overtorque / undertorque condition. Overtorque and Undertorque are determined by the settings in parameters L6-02 and L6-03. 0: Disabled 1: OL@SpdAgree - Alm (Overtorque Detection only active during Speed Agree and Operation continues after detection) 2: OL At RUN - Alm (Overtorque Detection is always active and operation continues after detection) 3: OL@SpdAgree - Flt (Overtorque Detection only active during Speed Agree and drive output will shut down on an OL3 fault.) 4: OL At RUN - Flt (Overtorque Detection is always active and drive output will shut down on an OL3 fault.) 5: UL@SpdAgree - Alm (Undertorque Detection is only active during Speed Agree and operation continues after detection.) 6: UL at RUN - Alm (Undertorque Detection is always active and operation continues after detection.) 7: UL @ SpdAgree - Flt (Undertorque Detection only active during Speed Agree and drive output will shut down on an OL3 fault.) 8: UL At RUN - Flt (Undertorque Detection is always active and drive output will shut down on an OL3 fault.)	Torque Detection Selection 1	L6-01
078	Overtorque detection level	Set unit: 1% Set range: 30-200% (100%= rated current of inverter)	0 to 300 Sets the overtorque/undertorque detection level as a percentage of Drive rated current.	Torque Detection Level 1	L6-02
079	Overtorque detection time	Set unit: 0.1sec and set range: 0.1-10.0sec	0.0 to 10.0 Sets the length of time an Over/Under torque condition must exist before torque detection 1 recognized by the Drive.	Torque Detection Time 1	L6-03
080	(timer function) ON Delay time	Set unit: 0.1sec Set range: 0.0-25.5sec	0.0 to 3000.0 Used in conjunction with a multi-function digital input and a multi-function digital output programmed for the timer function. This sets the amount of time between when the digital input is closed, and the digital output is energized.	Timer Function ON-Delay Time	b4-01

Appendix 3- Parameter Cross Reference

GPD506/P5 Parameter			P7 Parameter		
Param No. Nxxx	Parameter Name	Description or Selection	Description or Selection	Parameter Name	Param. No.
081	(timer function) Off delay time	Set unit: 0.1sec Set range: 0.0-25.5sec	0.0 to 3000.0 Used in conjunction with a multi-function digital input and a multi-function digital output programmed for the timer function. This sets the amount of time the output stays energized after the digital input is opened.	Timer Function OFF-Delay Time	b4-02
082	Braking resistor Overheat protection	0: Braking resistor overheat protection disabled. 1: Braking resistor overheat protection enabled.	Selects the DB protection only when using 3% duty cycle heatsink mount Yaskawa braking resistor. This parameter does not enable or disable the DB function of the Drive. 0: Not Provided 1: Provided	Internal Dynamic Braking Resistor Protection Selection	L8-01
083	Input open-phase detection level	Set unit:1% and set range: 1-100% (Open-phase detection disabled at set point =100%)	Monitors the DC Bus current ripple and activates when one of the input phases is lost (PF).	Input Phase Loss Detection Level	L8-06
084	(PID control) PID control selection	0: PID control disabled. 1: PID control enabled. (D=Fdbk) 2: PID control enabled. (D=Fdfwd) 3: PID control enabled. (D=Fdbk, feedback=reverse)	This parameter enables / disables the closed loop (PI) controller. 0: Disabled 1: Enabled (commanded speed becomes PI setpoint) 3: Fref+PI	PI Mode Setting	b5-01
086	(PID control) Proportional gain	Set unit: 0.1 Set range: 0.0-10.0	0.00 to25.00 Sets the proportional gain of the PID controller.	Proportional Gain Setting	b5-02
087	(PID control) Integral time	Set unit: 0.1sec Set range: 0.0-100.0sec	0.0 to 360.0 Sets the integral time for the PID controller. A setting of zero disables integral control.	Integral Time Setting	b5-03
089	(PID control) Integration upper limit	Set unit: 1% Set range: 0-109%	0.0 to100.0 Sets the maximum output possible from the integrator. Set as a% of maximum frequency.	Integral Limit Setting	b5-04
090	PID Feedback loss detection selection	0: PID feedback loss disabled. 1: PID feedback loss enabled, no fault detected. 2: PID feedback loss enabled, fault detection enabled.	0: Disabled 1: Alarm 2: Fault	PI Feedback Reference Missing Detection Selection	b5-12
091	PID Feedback loss detection level	Set unit:1% Set range: 0-100%	0 to 100 Sets the PID feedback loss detection level as a percentage of maximum frequency (E1-04).	PI Feedback Loss Detection Level	b5-13
092	PID Feedback loss detection time	Set unit: 0.1sec Set range: 0.0-25.5sec	0.0 to 25.5 Sets the PID feedback loss detection delay time in terms of seconds.	PI Feedback Loss Detection Time	b5-14
093	PID output reverse-characteristic	0: Reverse-characteristic disabled 1: Reverse-characteristic enabled.	Determines whether the PID controller will be direct or reverse acting. 0: Normal Output (direct acting) 1: Reverse Output (reverse acting)	PI Output Level Selection	b5-09
094	PID Sleep function operation level	Set unit: 0.1Hz Set range: 0.0-400.0Hz	0.0 to 200.0 Sets the sleep function start frequency.	Sleep Function Start Level	b5-15
095	PID Sleep function operation time	Set unit: 0.1sec Set range: 0.0-25.5sec	0.0 to 25.5 Sets the sleep function delay time in terms of seconds.	Sleep Delay Time	b5-16
096	Energy Saving Selection	0: Energy saving disabled 1: Energy saving enabled	Energy Savings function enable/disable selection. 0: Disabled 1: Enabled	Energy Saving Control Selection	b8-01
098	Energy Save Voltage Lower limit @ 60 Hz	Set unit: 1% Set range: 0-120%	Used to fine-tune the energy savings function when in V/F control method.	Power Detection Filter Time	b8-05
099	Energy Save Voltage Lower limit @ 6 Hz	Set unit:1% Set range:0-25%		Search Operation Voltage Limit	b8-06

Appendix 3- Parameter Cross Reference

GPD506/P5 Parameter			P7 Parameter		
Param No. Nxxx	Parameter Name	Description or Selection	Description or Selection	Parameter Name	Param. No.
100	Time of average KW	Set unit:1 (1=25ms) Set range: 1-200 (25ms=5.0sec)	0 to 2000 Used to fine-tune the energy savings function when in V/F control method.	Power Detection Filter Time	b8-05
101	MEMOBUS timeout detection	0: Timeout detection disabled. 1: Timeout detection enabled.	Enables or disables the communications timeout fault (CE). 0: Disabled - A communication loss will not cause a communication fault. 1: Enabled - If communication is lost for more than 2 seconds, a CE fault will occur.	Communication Error Detection Selection	H5-05
102	MEMOBUS Stop method selection at communication error (CE)	0: Deceleration stop (Decelerate by deceleration time 1) 1: Coast stop 2: Deceleration stop (Decelerate by deceleration time 2) 3: Continue operation (alarm display)	Selects the stopping method when a communication timeout fault (CE) is detected. 0: Ramp to Stop 1: Coast to Stop 2: Fast-Stop 3: Alarm Only 4: Run at d1-04	Stopping Method after Communication Error	H5-04
104	MEMOBUS Slave address	Set unit:1 Set range:0-31 (There is no MEMOBUS communication at set point =0)	0 to 20 Hex Selects Drive station node number (address) for Modbus terminals R+, R-, S+, S-. The Drive's power must be cycled for the setting to take effect.	Drive Node Address	H5-01
105	MEMOBUS Baud rate selection	0: 2400bps 1: 4800bps 2: 9600bps	Selects the baud rate for Modbus terminals R+, R-, S+ and S-. The Drive's power must be cycled for the setting to take effect. 0: 1200 bps 1: 2400 bps 2: 4800 bps 3: 9600 bps 4: 19200 bps	Communication Speed Selection	H5-02
106	MEMOBUS Parity selection	0: Parity none 1: Even parity 2: Odd parity	Selects the communication parity for Modbus terminals R+, R-, S+ and S-. The Drive's power must be cycled for the setting to take effect. 0: No Parity 1: Even Parity 2: Odd Parity	Communication Parity Selection	H5-03
108	Motor no-load current	Set unit: 1% Set range: 0-99% (100%= rated current of motor)	Set to the magnetizing current of the motor as a percentage of full load amps (E2-01). This value is automatically set during rotational Auto-Tuning.	No-Load Current	E2-03
110	Operator Connection Fault Detect Select	0: Operator connection fault disabled. 1: Operator connection fault enabled.	Determines if the Drive will stop when the Digital Operator is removed when in LOCAL mode or b1-02=0. 0: Disabled - The Drive will not stop when the Digital Operator is removed. 1: Enabled - The Drive will fault (OPR) and coast to stop when the operator is removed.	Operation Selection when Digital Operator is Disconnected	o2-06
111	Local/remote Change- over function Select	0: Cycle External run 1: Accept external run	0: Cycle External RUN - If the run command is closed when switching from local mode to remote mode, the Drive will not run. 1: Accept External RUN - If the run command is closed when switching from local mode to remote mode, the Drive will run.	Local/Remote Run Selection	b1-07
112	Low frequency OL starting point	Set unit: 0.1Hz Set range: 0.0-10.0Hz	This parameter assists in protecting the output transistors from overheating when output current is high and output frequency is low (6Hz and less).	OL2 Characteristic Selection at Low Speeds	L8-15
113	Continuous running level at 0Hz	Set unit: 1% Set range: 25-100%	0: Disabled 1: Enabled (L8-18 is active)		

Appendix 3- Parameter Cross Reference

GPD506/P5 Parameter			P7 Parameter		
Param No. Nxxx	Parameter Name	Description or Selection	Description or Selection	Parameter Name	Param. No.
115	KVA selection	Set unit: 1 Set range: PC5 (0~8, 20~29), GPD506/P5(9~F, 2A~35)	0 to FF Sets the kVA of the Drive. Enter the number based on Drive model number. Use the last four digits of the model number. CIMR-P7U This parameter only needs to be set when installing a new control board. Do not change for any other reason. Refer to Table B.1. in the P7 Instruction Manual	Drive/kVA Selection	o2-04
116	CT/VT selection	0: Constant Torque selection 1: Variable Torque selection	Selects Drive's rated input and output current, overload capacity, carrier frequency, current limit, and maximum output frequency. See Introduction for details. 1: Normal Duty 1 2: Normal Duty 2	Reduced Current Rating Standard Current Rating	C6-01

Appendix 3- Parameter Cross Reference

Page left intentionally blank

GPD506/P5 to P7 Product Transition Guide



Yaskawa Electric America, Inc
16555 W. Ryerson Rd
New Berlin, WI
(800)YASKAWA (927-5292) Fax (262) 782-3418
www.drives.com